

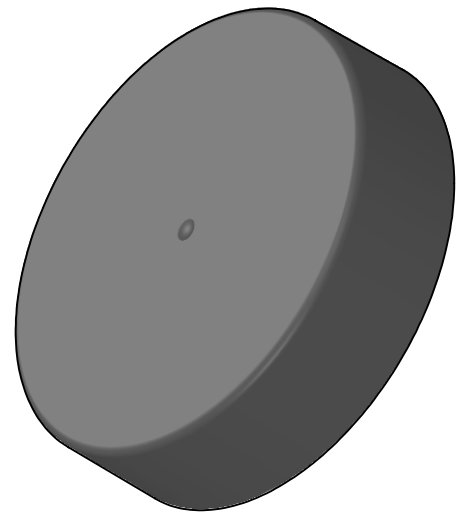

**OUTSIDE SURFACES SPI "A-3" OR BETTER  
INSIDE SURFACES SPI "B-3" OR BETTER.**

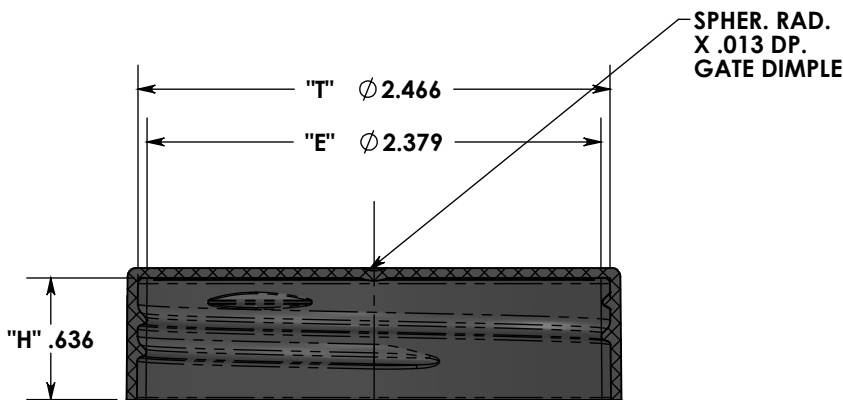

**SECTION D-D**

**THREAD DATA:  
SP'L 63-445 FINISH  
.167 PITCH (6 T.P.I.)  
1 1/4 TURNS OF THD.**

**ADVERTISING DRAWING  
NOT FOR QUALITY CONTROL**

PROPRIETARY AND CONFIDENTIAL <small>THE INFORMATION CONTAINED IN THIS DRAWING IS THE SOLE PROPERTY OF COMET TOOL Co. ANY REPRODUCTION IN PART OR AS A WHOLE WITHOUT THE WRITTEN PERMISSION OF COMET TOOL Co. IS PROHIBITED.</small>		 <b>COMET TOOL COMPANY</b> 651 LAMBS RD., PITMAN, N.J 08071-2042	
MATERIAL <b>POLYPROPYLENE</b>		<b>TITLE:</b> <b>SPECIAL 63-445 CT CLOSURE SMOOTH FINISH</b>	
DRAWN BY <b>JJM</b>	PLASTIC PART NO. <b>1340-0048</b>	PLASTIC PART REV. <b>B</b>	DWG. NO. <b>1340-0048-EXP</b>
		SIZE <b>A</b>	REV <b>B</b>
		DATE <b>11/3/10</b>	
		SCALE: 1:1	
		SHEET 2 OF 2	